

REQUEST FOR INFORMATION

25 August 2008

Presented to IDP Advisory Committee
NAAB, NCARB, AIA, ACSA

v. 1.01
prepared by
Matthew Arnold AIA NCARB

Matthew Arnold Architecture & Design
20082 Dairy Lane
Sterling VA 20165

matt@stairwaytoarchitecture.com

PATH TO LICENSURE

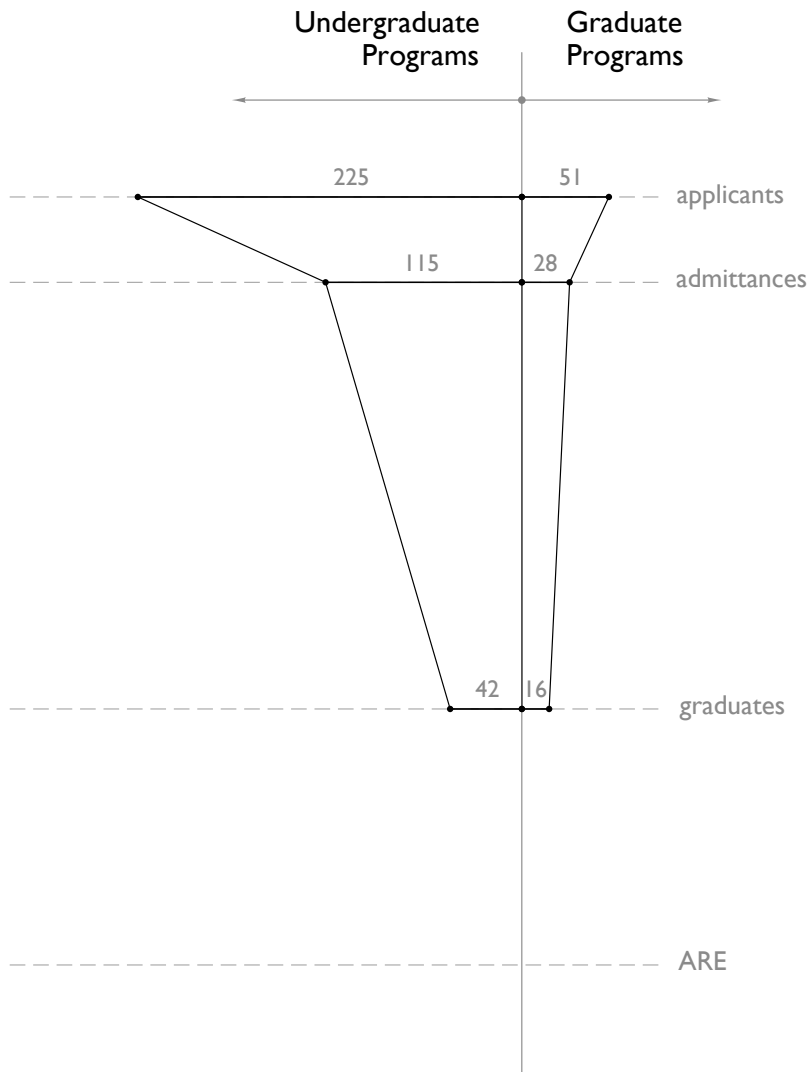

Diagrams showing applicants, admittances, and graduates Accredited Schools of Architecture in the US 2005 & 2006 data

**Composite
pre-prof Bachelors
4 year program
52 programs**

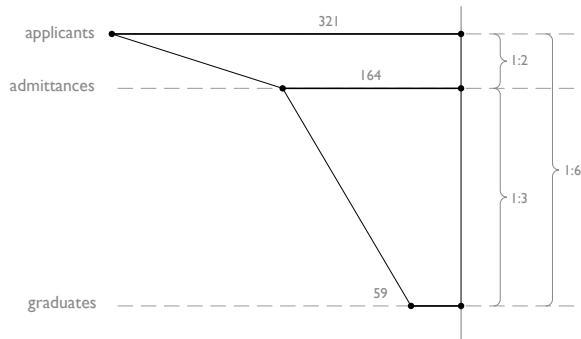

**Composite
B. Arch program
5 year program
57 programs**

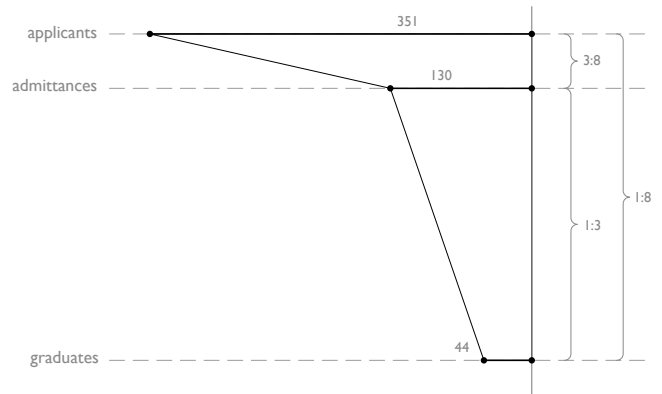

**Composite
M. Arch
5 year program
17 programs**

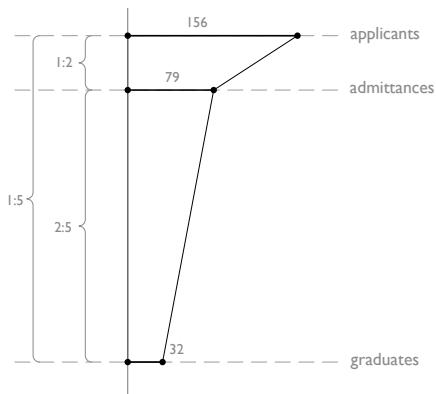

**Composite
post non-professional M.Arch
3 year program
44 programs**

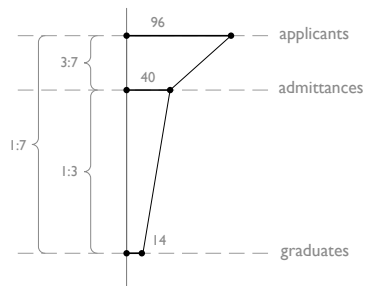

note:
The path to licensure for holders of 4-year pre-professional degrees passes through a masters program.

**Composite
post-professional M.Arch
2 year program
53 programs**

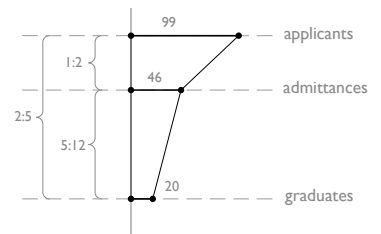

100 students
scale of diagrams

Diagrams showing total enrollment, faculty composition, matriculation latency Accredited Schools of Architecture in the US 2005 & 2006 data

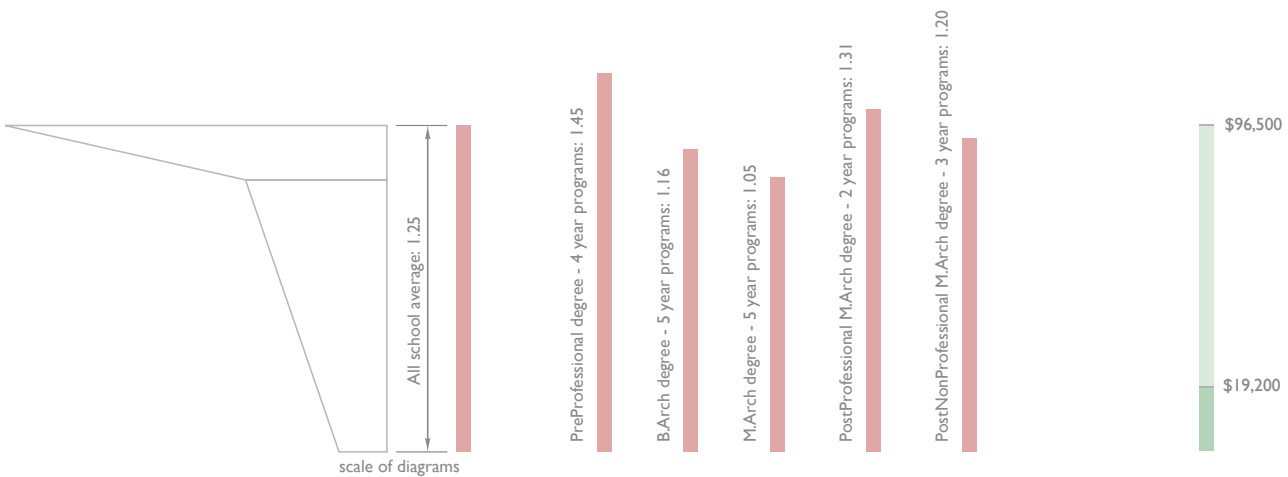
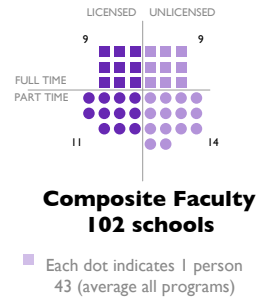
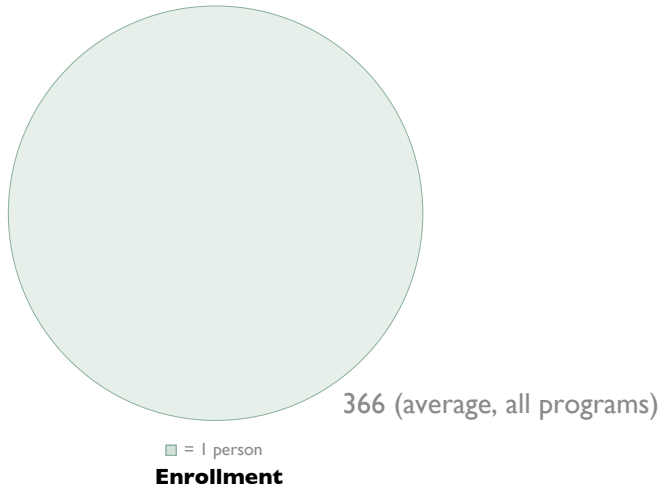

Total Enrollment :: (Graduates) x (# years in degree offered)

■ = annual total school tuition / graduate
■ = annual school tuition / student

Matriculation Latency

Tuition

Diagrams showing IDP enrollment, ARE pass rates by division, ARE cumulative pass rates, duration of IDP 2007 data

Note: Data not available for IDP enrollment, ARE cumulative pass rates, duration of IDP

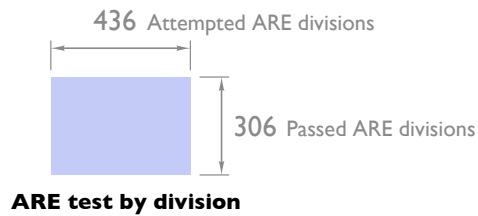

ARE attempts and pass rates (by division)
All applicants nationally

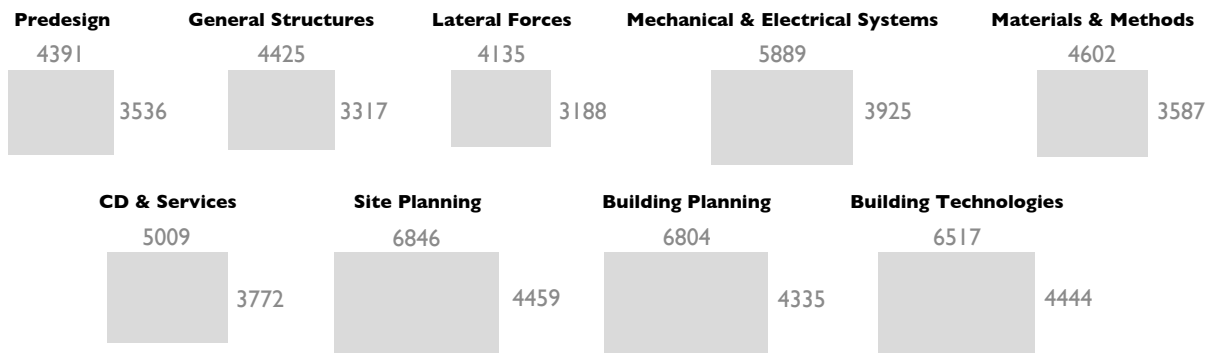

Andrews University

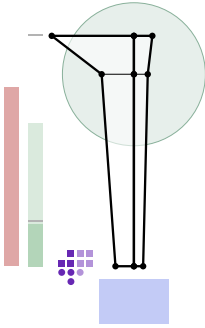

Arizona State University

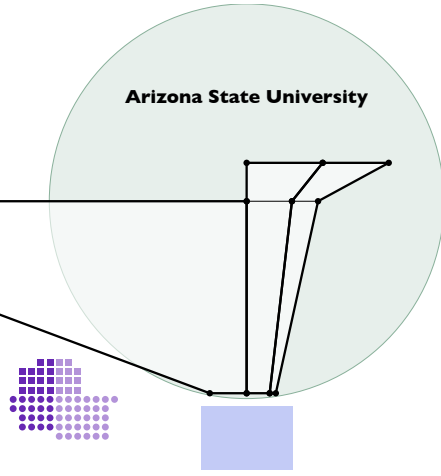

Auburn University

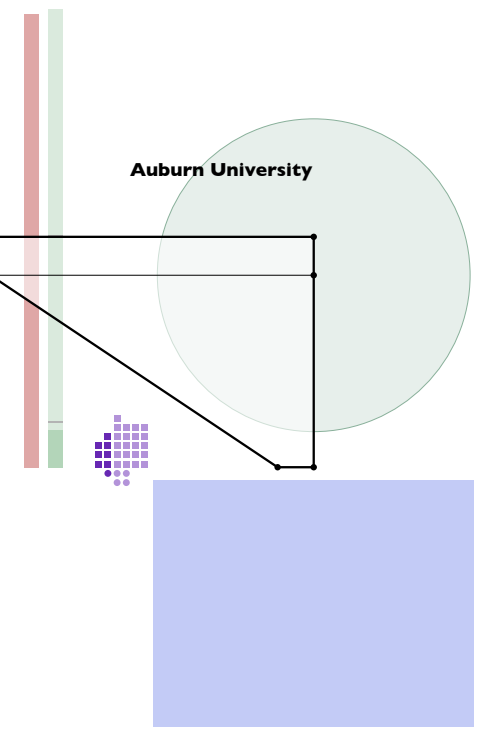

Boston Architectural College

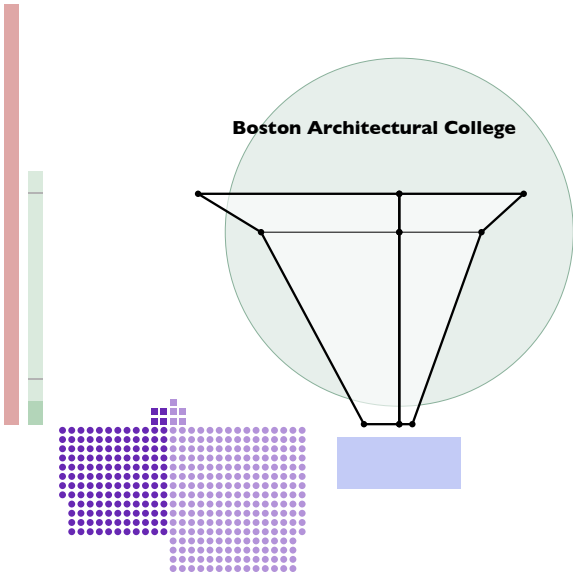

Ball State University

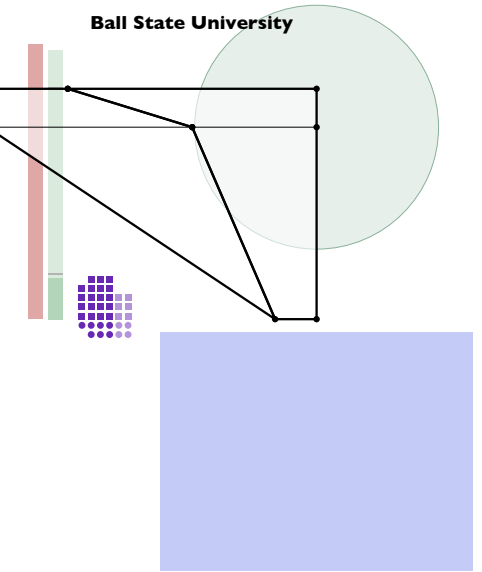

California Polytechnic State University

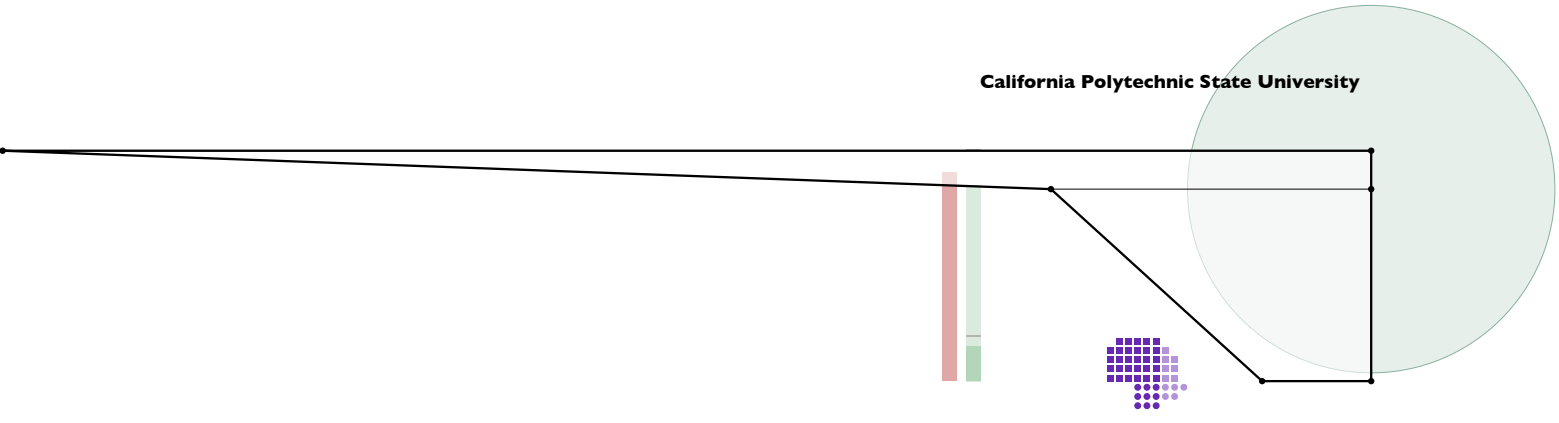

California State Polytechnic University - Pomona

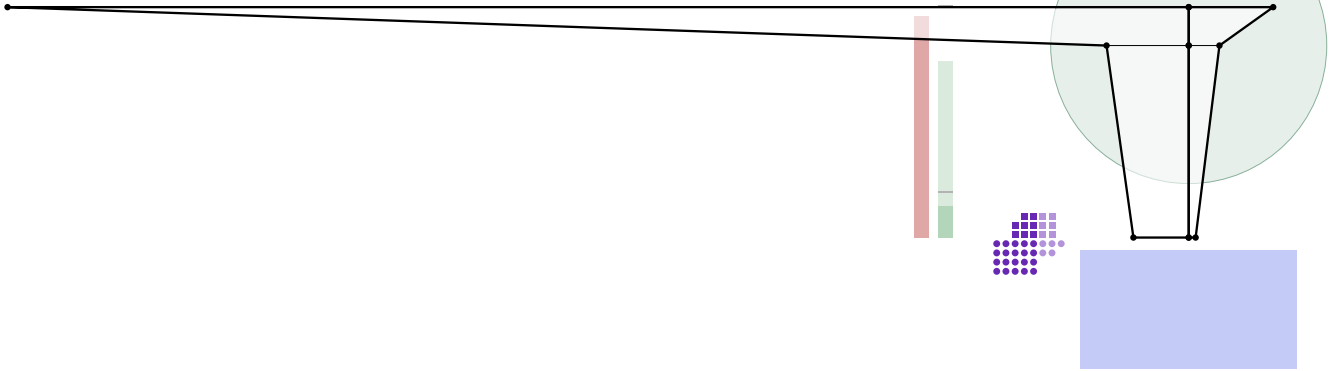

California College of Arts and Crafts

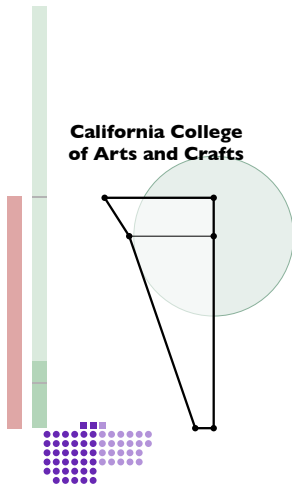

Catholic University of America

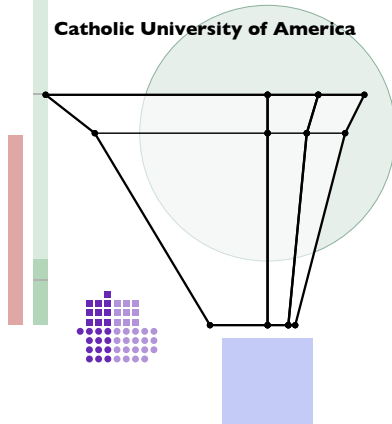

City College of CUNY

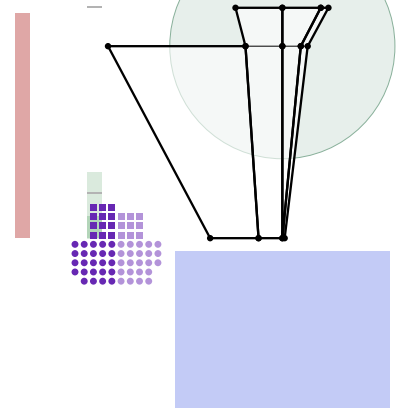

Cooper Union for the Advancement of Science and Art

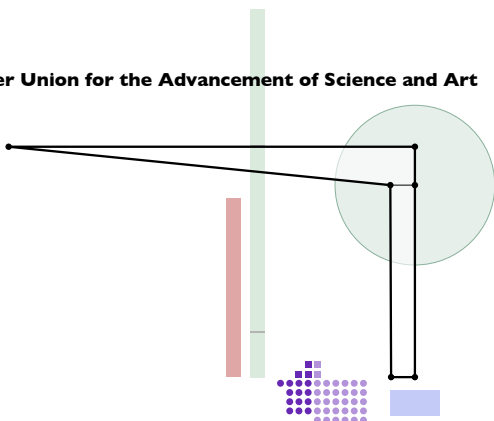

Cornell University

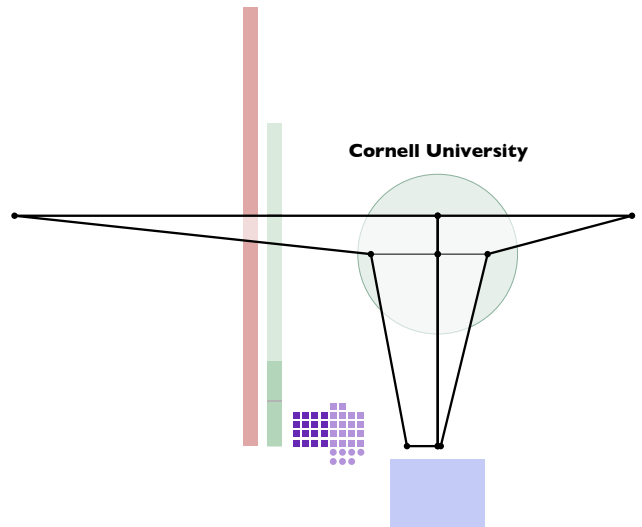

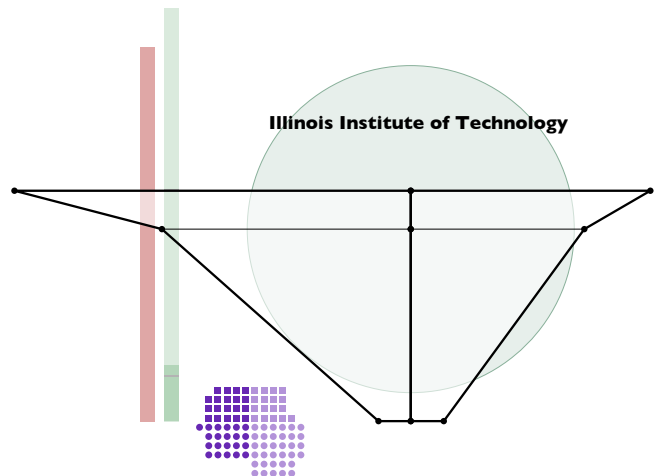
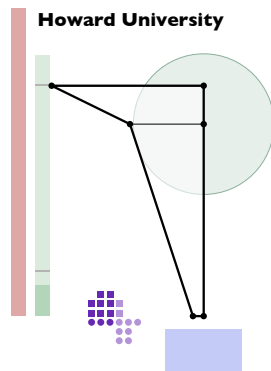
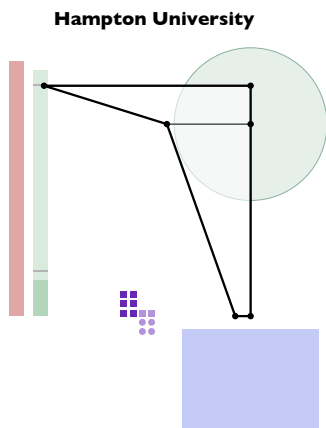
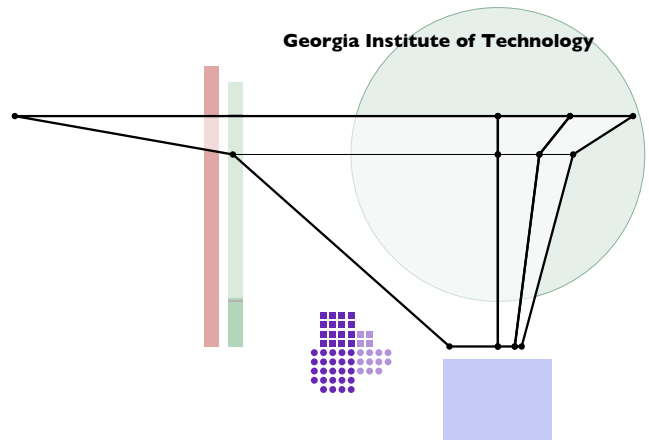
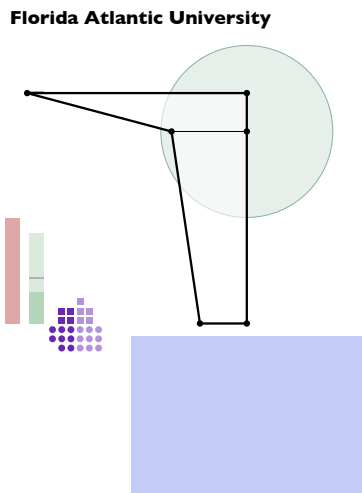
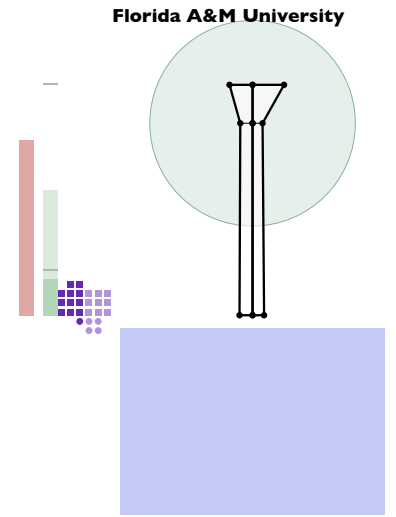
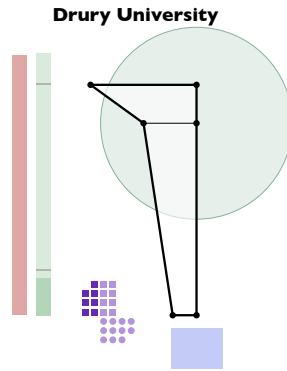
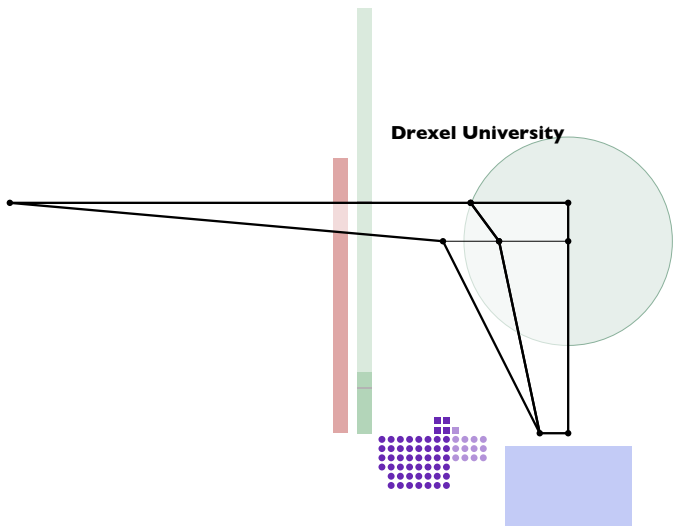

Iowa State University

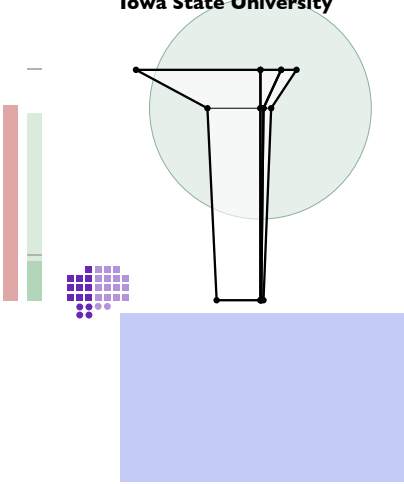

Judson University

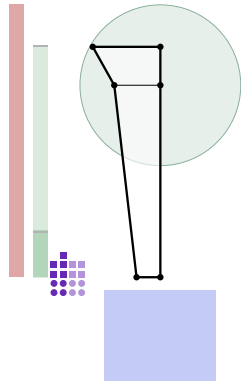

Kansas State University

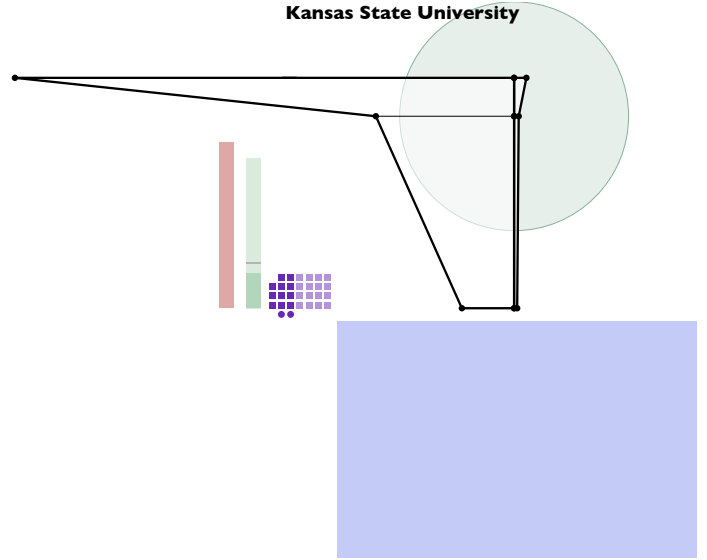

Kent State University

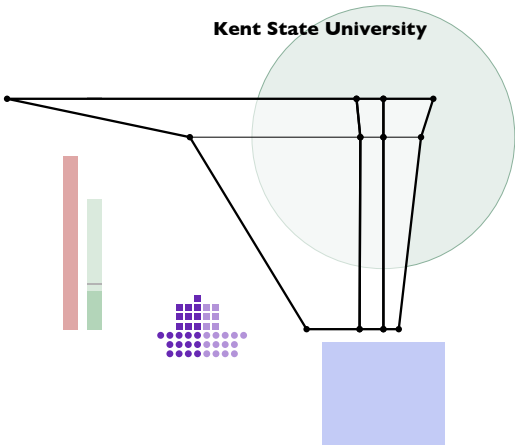

Lawrence Technological University

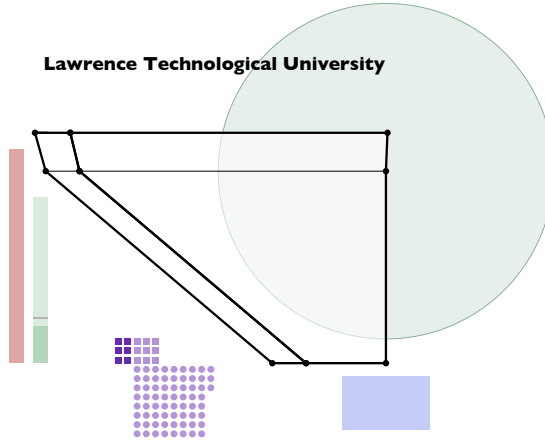

Louisiana State University

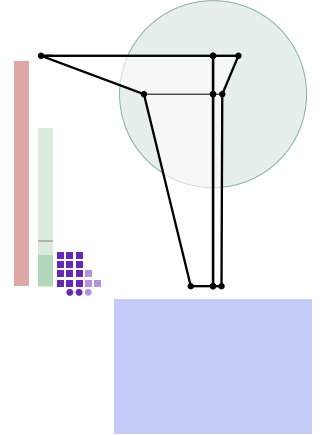

Massachusetts Institute of Technology

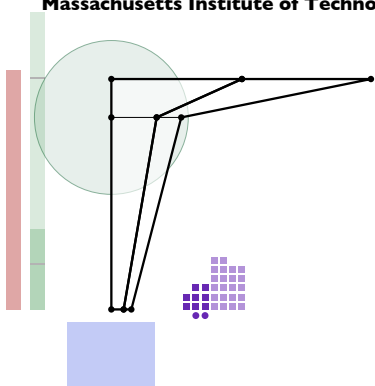

Miami University

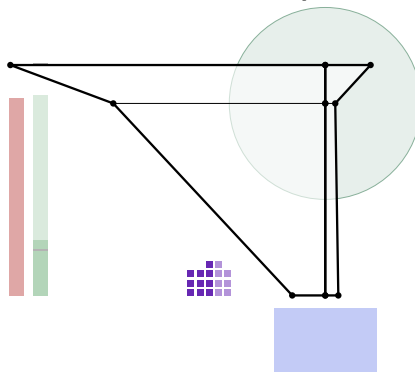

Mississippi State University

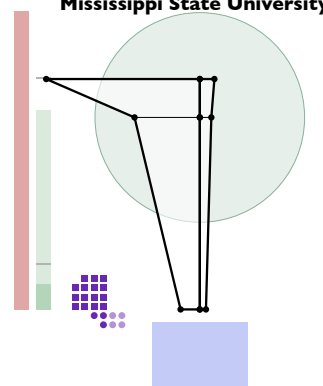

Montana State University

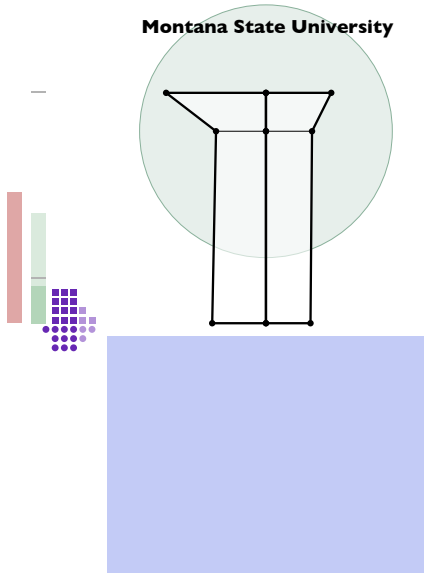

Morgan State University

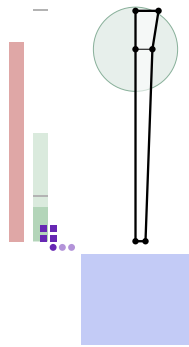

New Jersey Institute of Technology

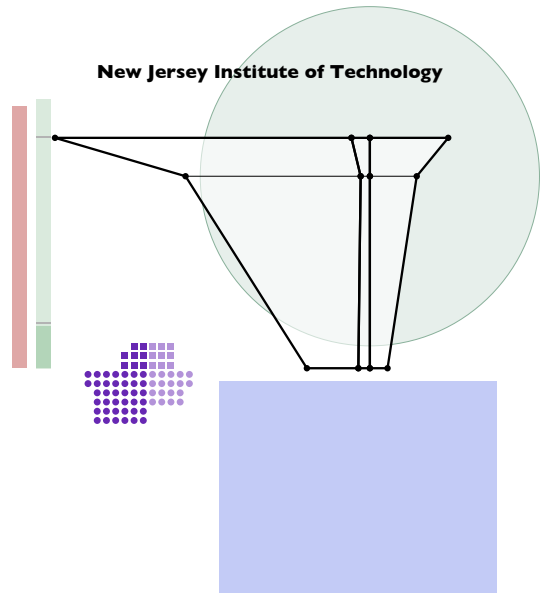

New School of Architecture and Design, San Diego

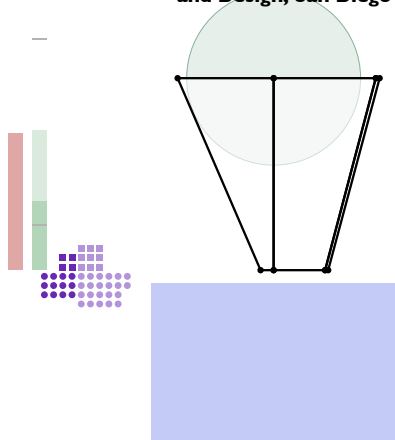

New York Institute of Technology

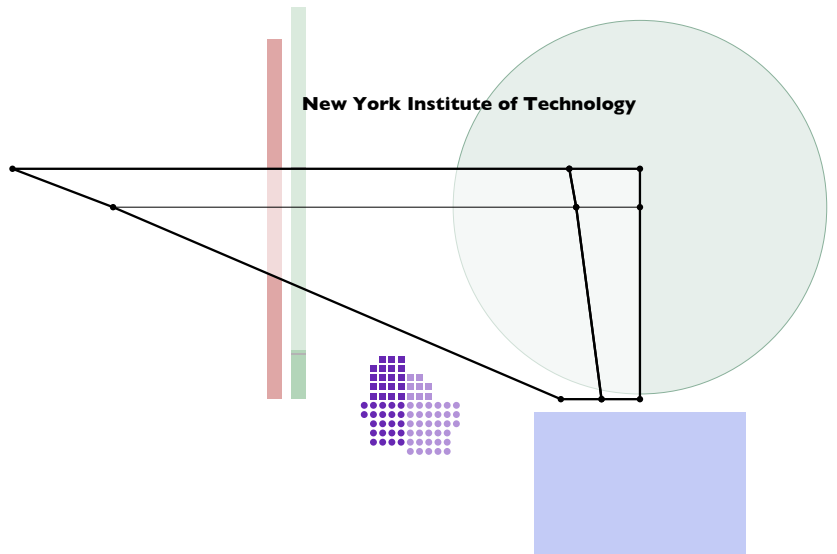

North Carolina State University

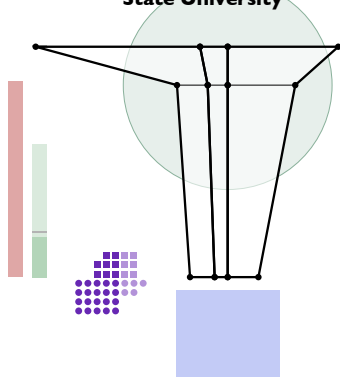

North Dakota State University

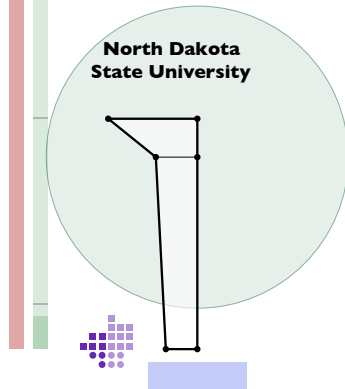

Norwich University

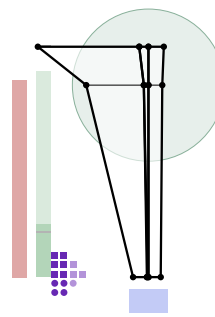

Ohio State University

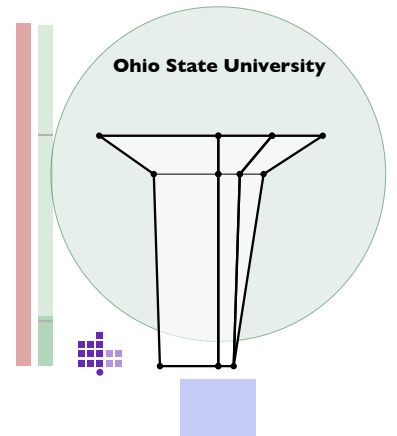

Oklahoma State University

Parsons School of Design

Pennsylvania State University

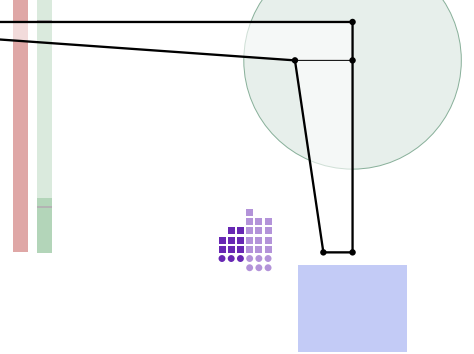
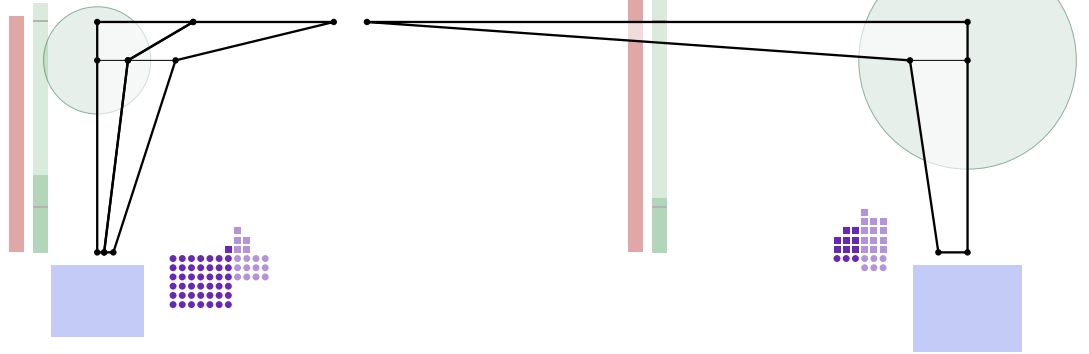
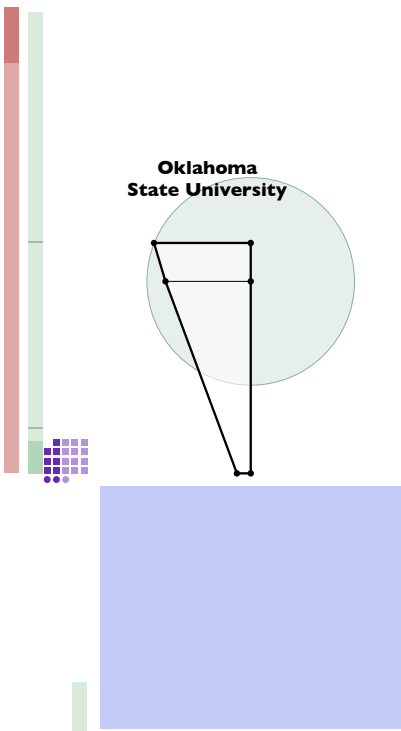

Pratt Institute

Princeton University

Rice University

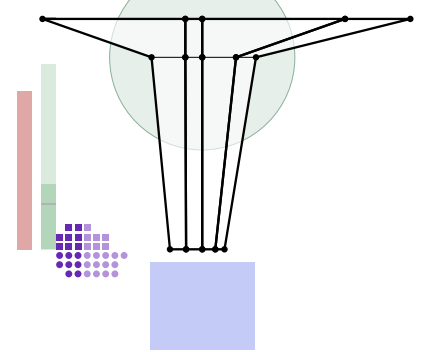
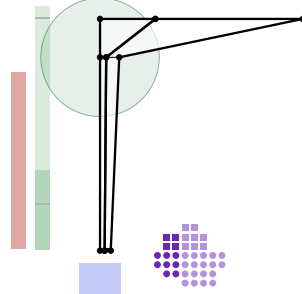
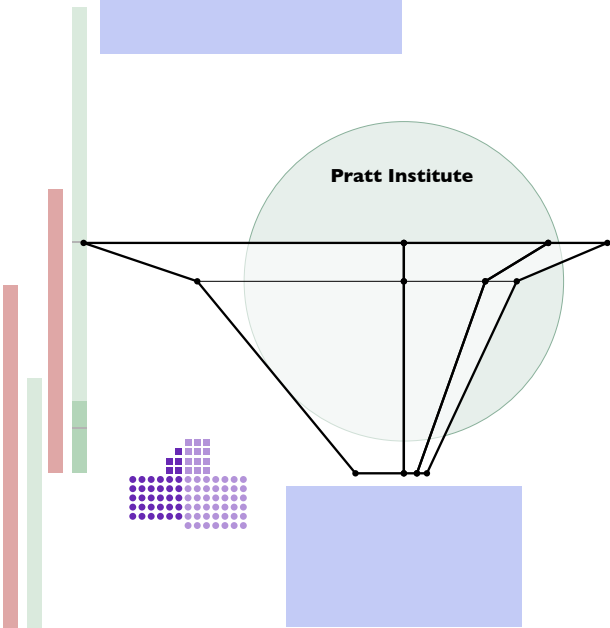

Prairie View A&M University

Roger Williams University

Savannah College of Art and Design

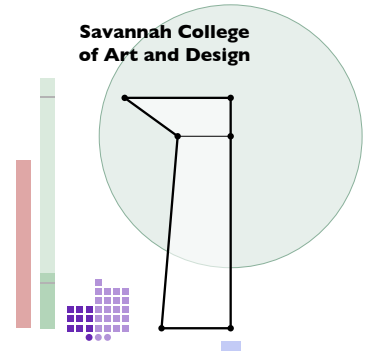
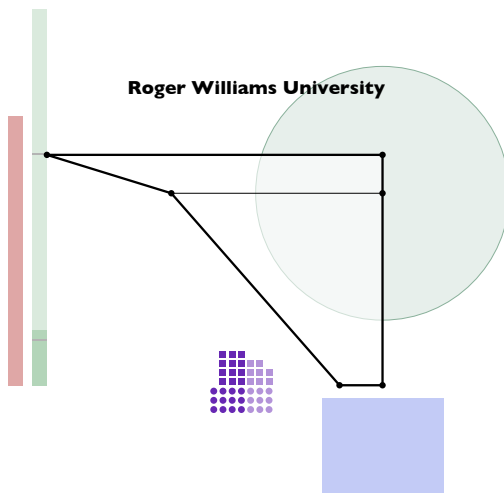
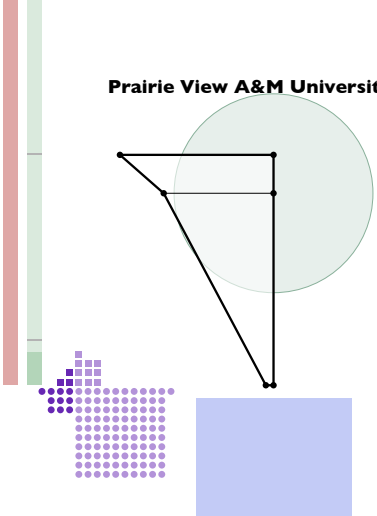

Southern California Institute of Architecture

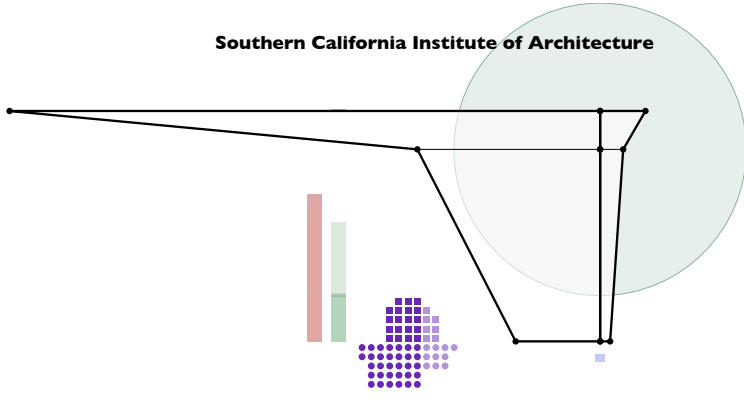

Southern Polytechnic State University

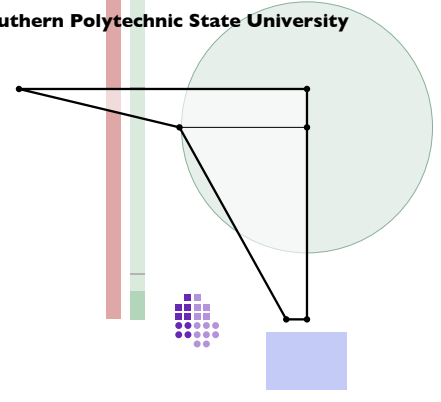

Southern University and A&M College



SUNY at Buffalo

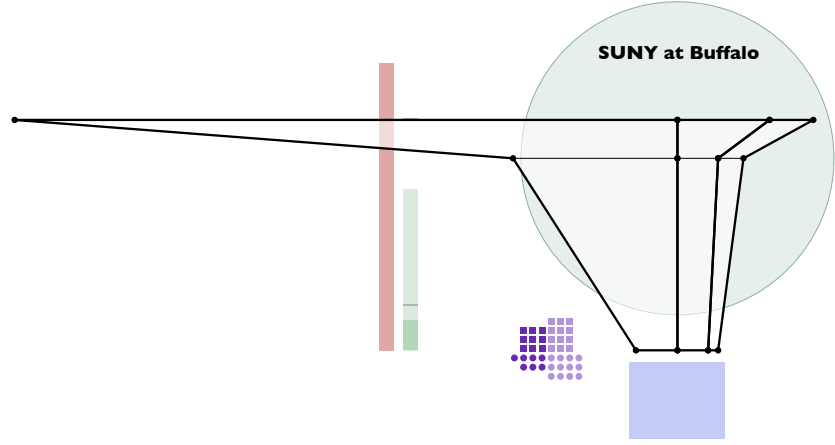

Syracuse University

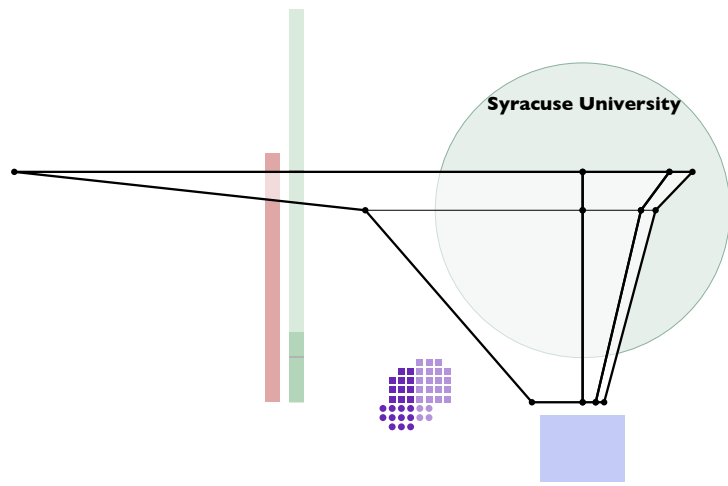

Taliesin

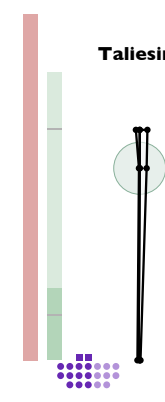

Temple University

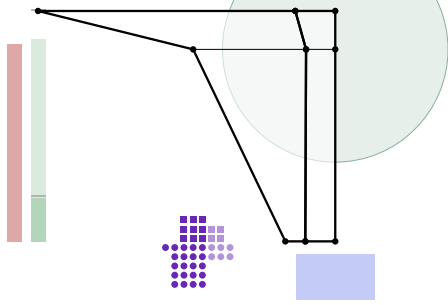

Texas A&M University

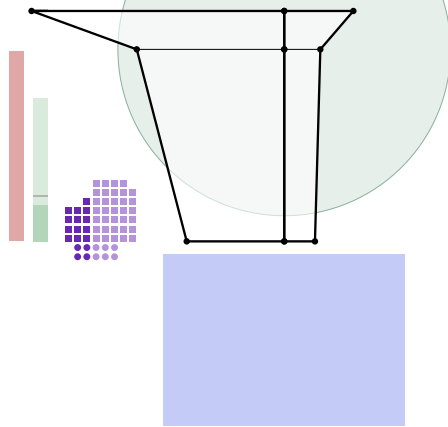

Tulane University

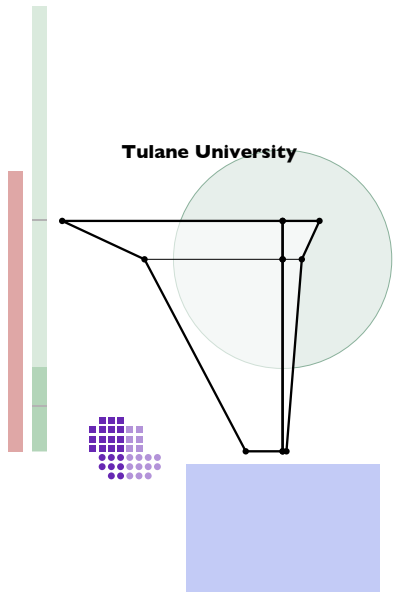

University of Arkansas

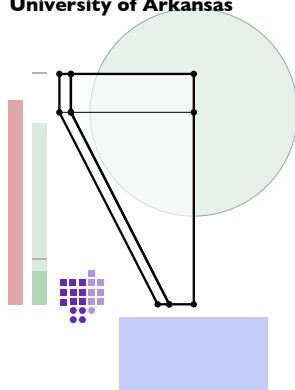

University of California - Los Angeles

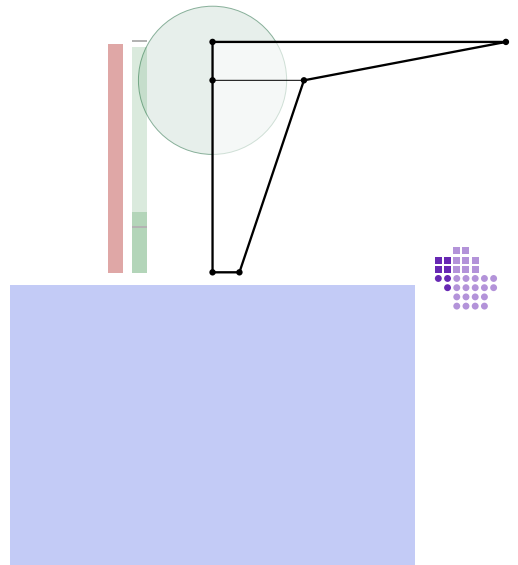

University of Colorado

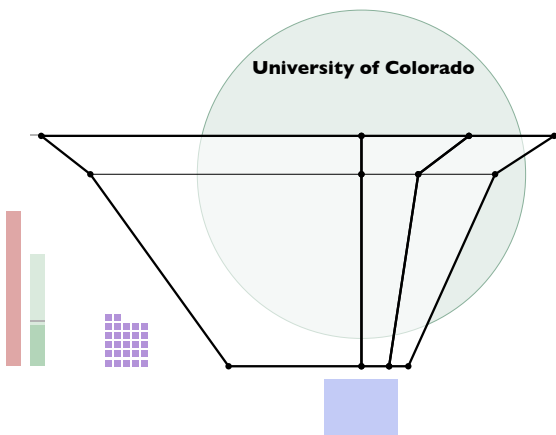

**University of Detroit,
Mercy**

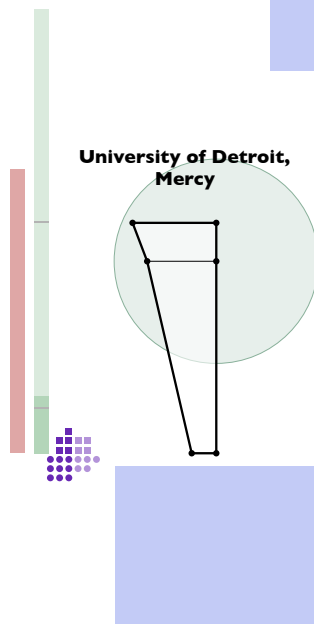

University of Florida

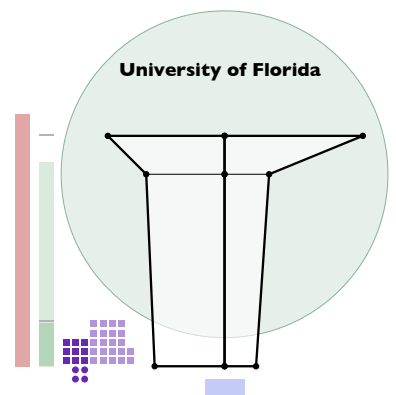

University of Houston

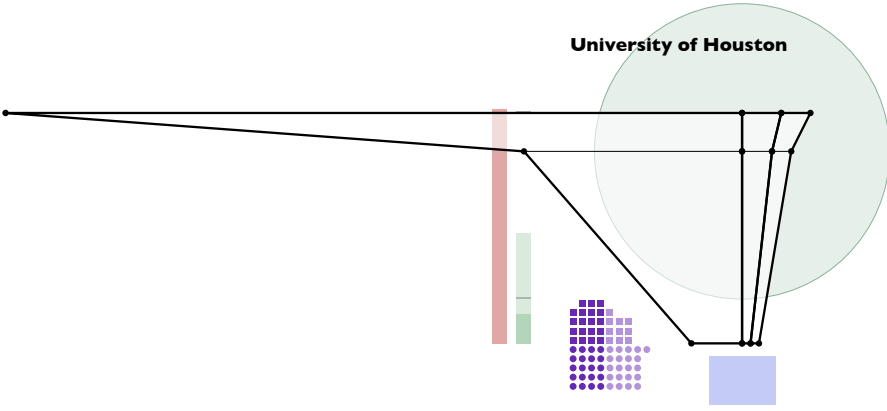

University of Idaho

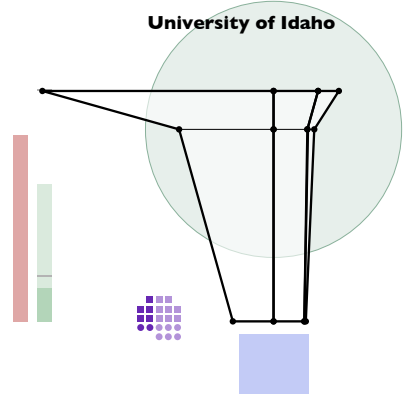

University of Illinois, Chicago

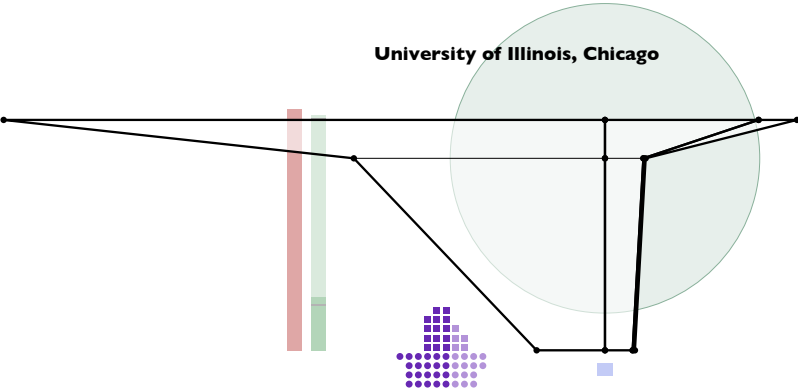

University of Kansas

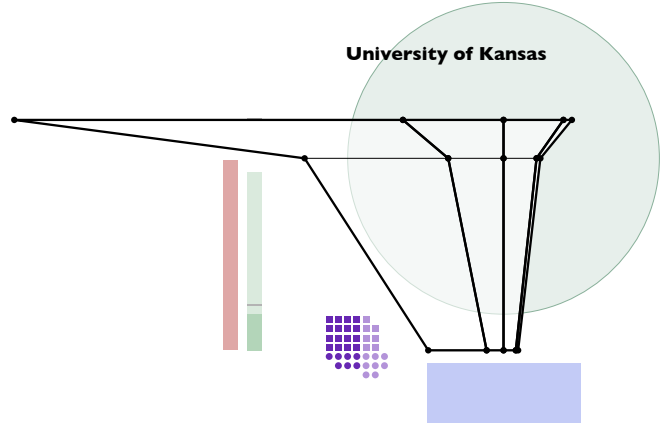

University of Kentucky

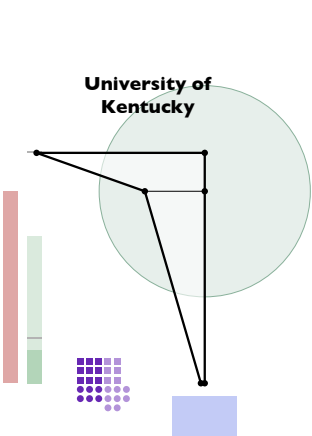

University of Louisiana, Lafayette

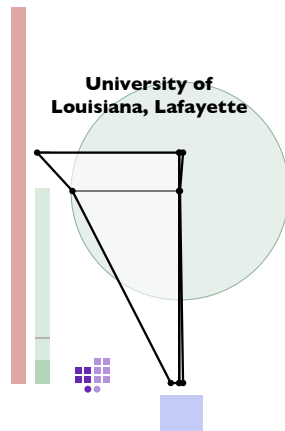

University of Maryland

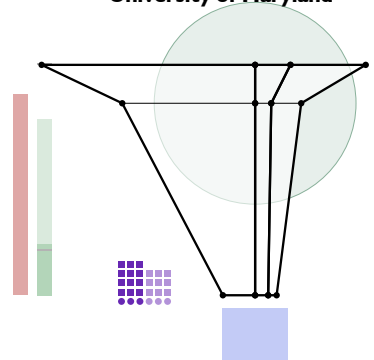

University of Massachusetts

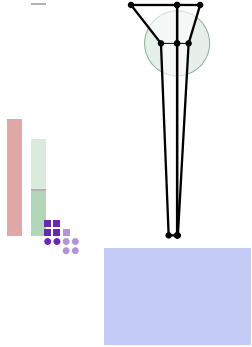

University of Miami

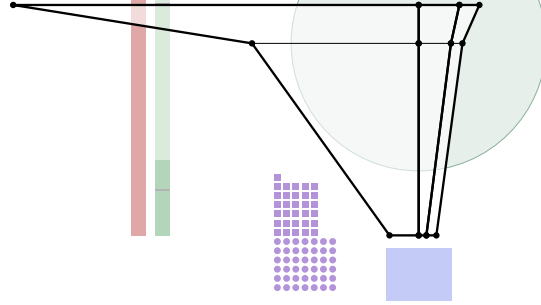

University of Michigan

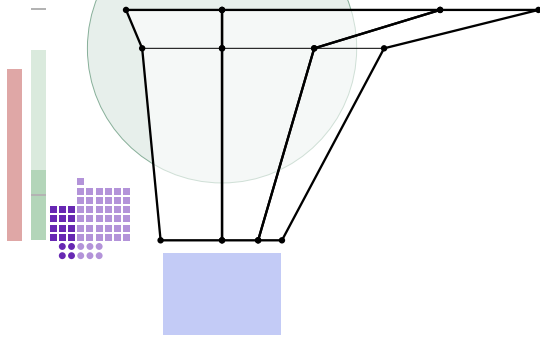

University of Nebraska, Lincoln

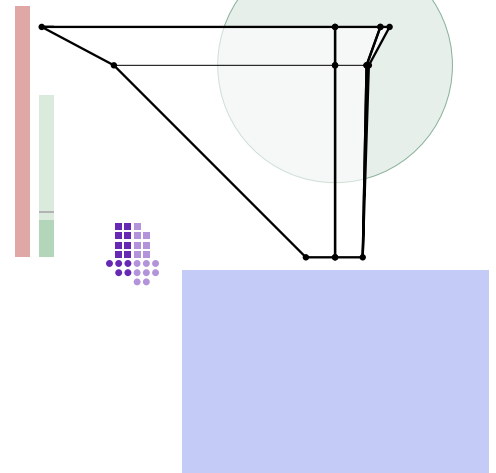

University of Nevada, Las Vegas

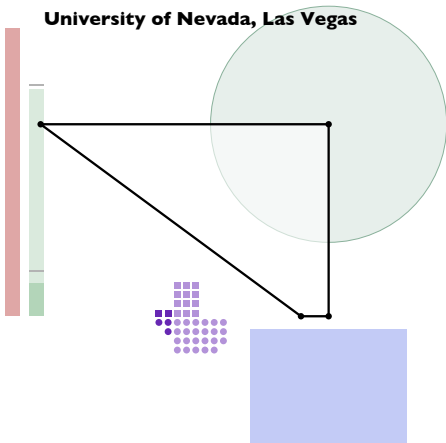

University of New Mexico

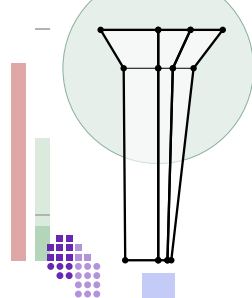

University of North Carolina, Charlotte

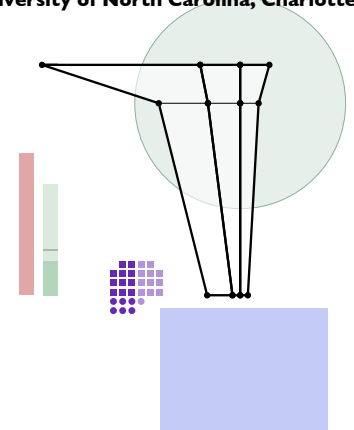

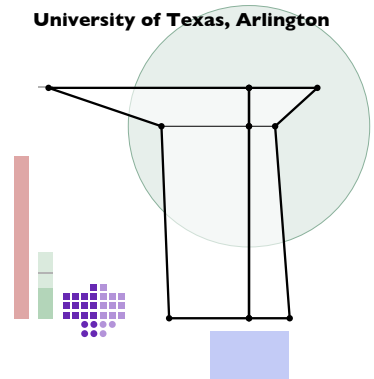
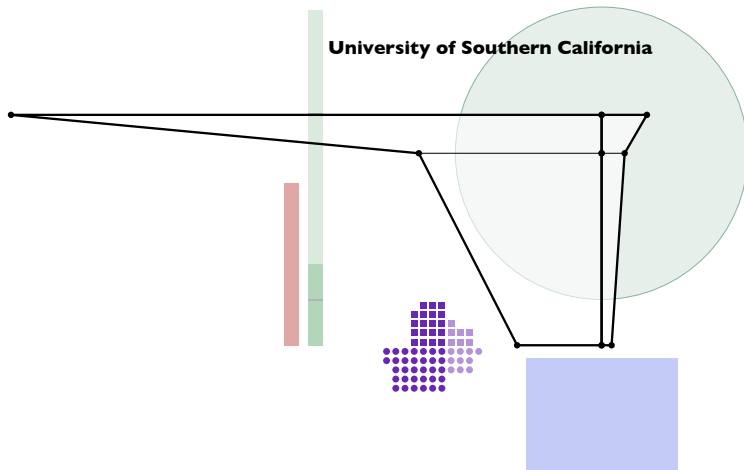
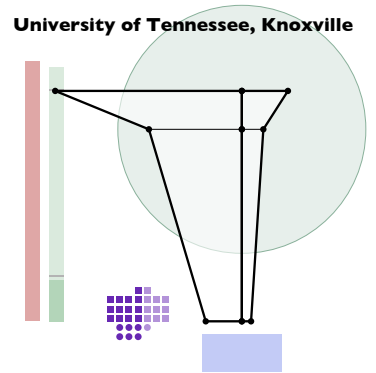
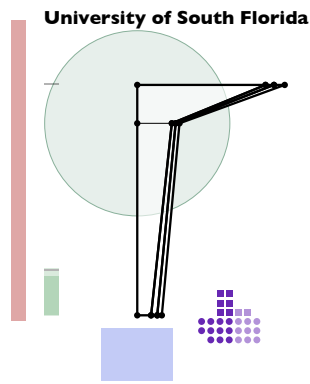
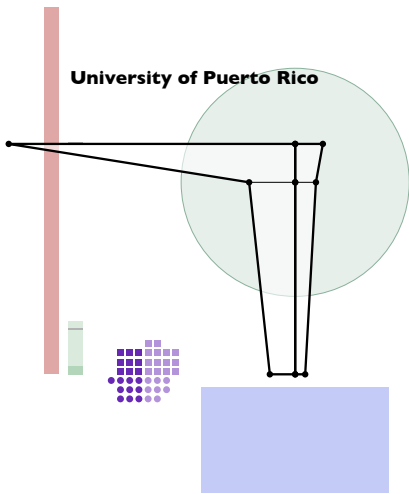
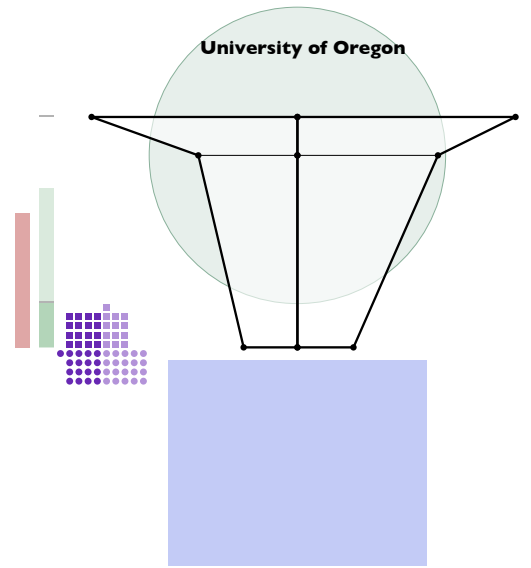
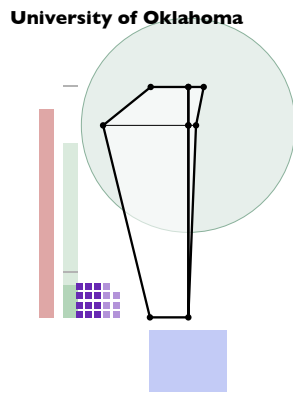
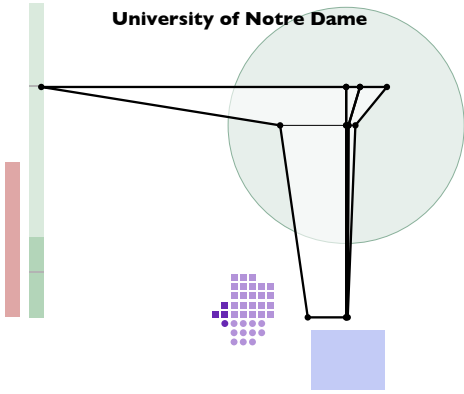

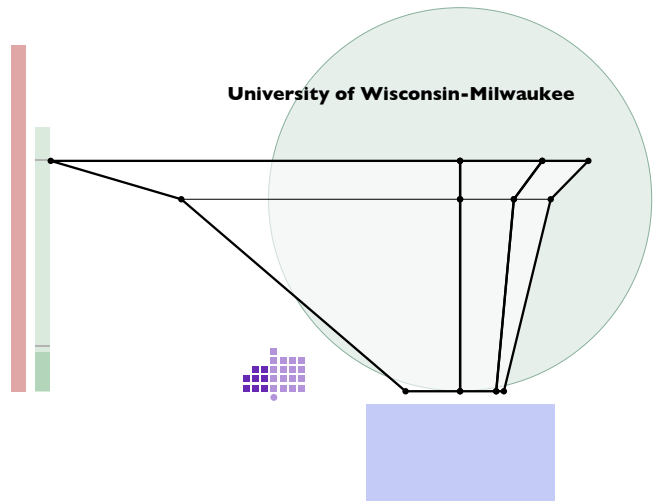
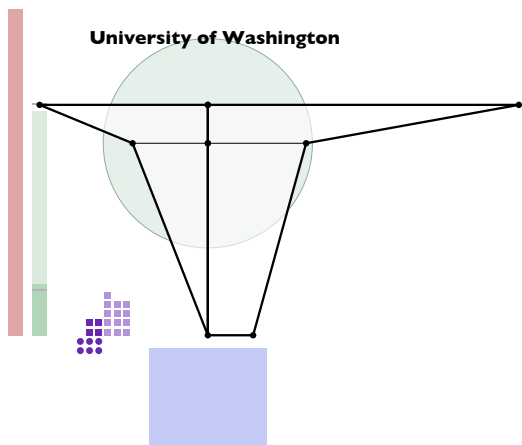
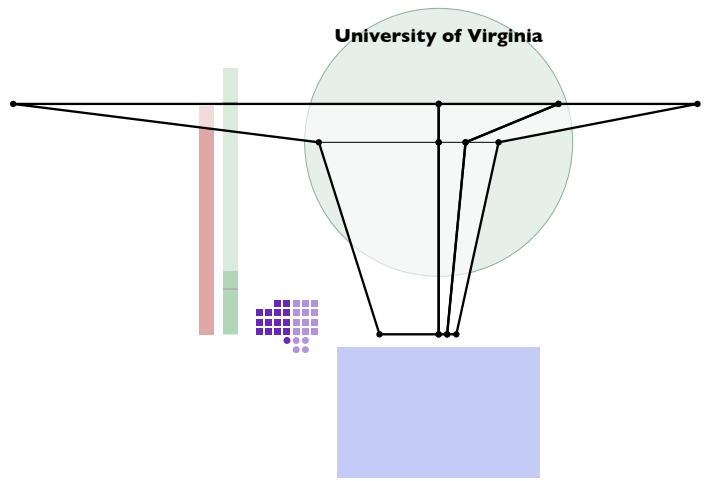
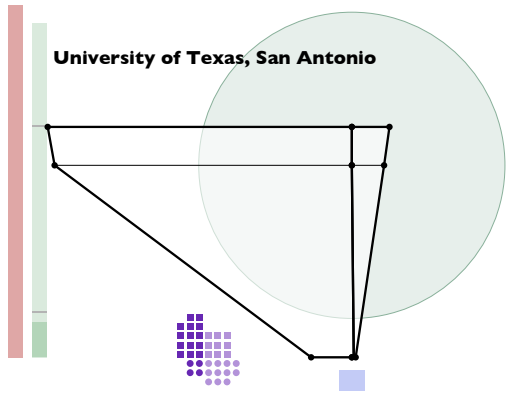
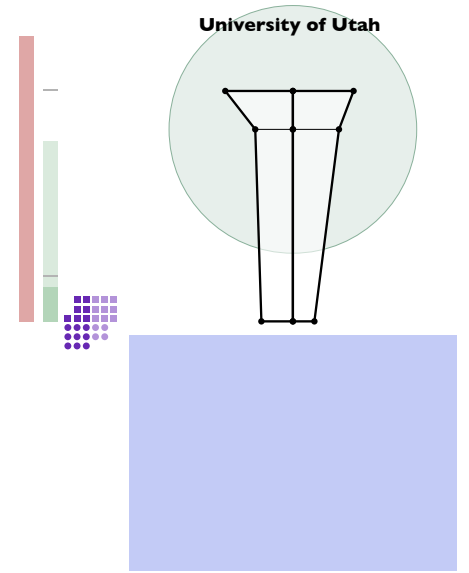
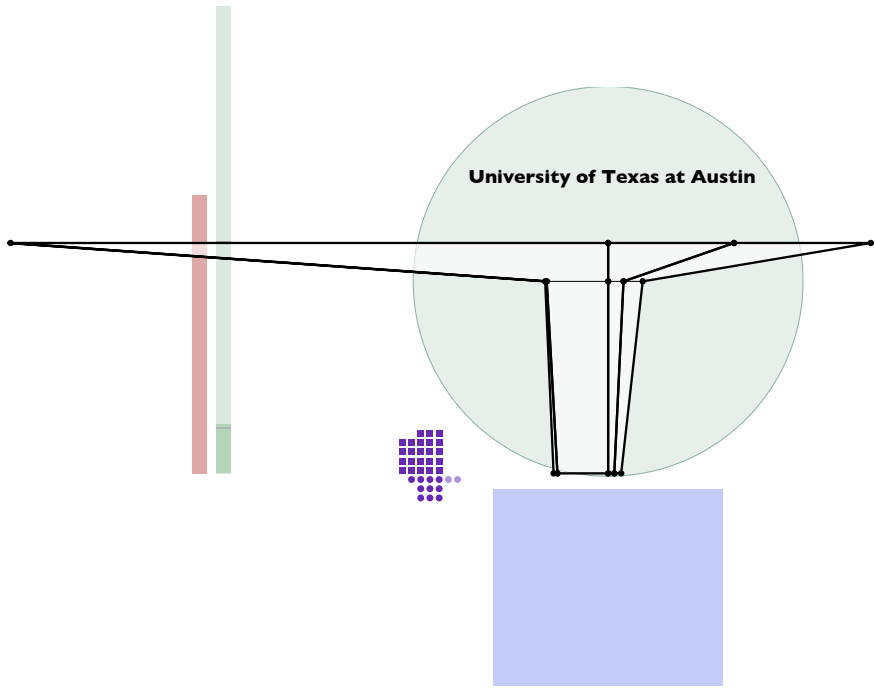

Virginia Polytechnic Institute & State University

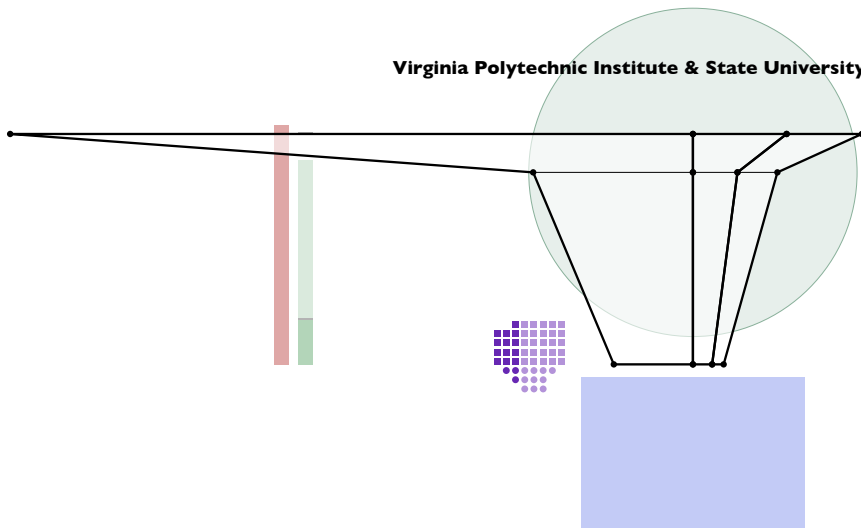

Washington University in St. Louis

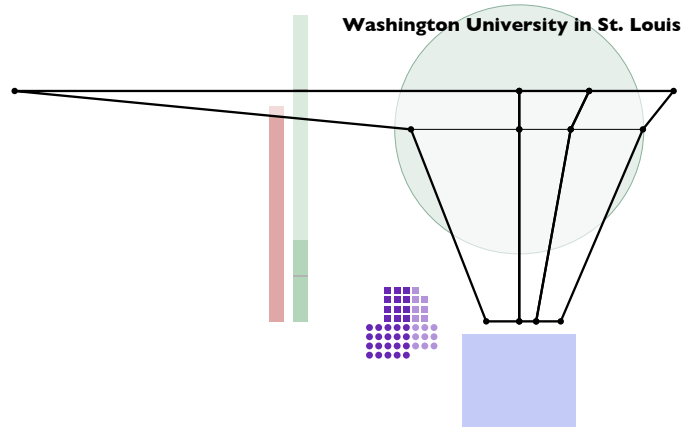

Washington State University

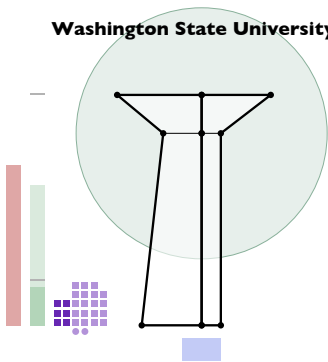

Wentworth Institute of Technology

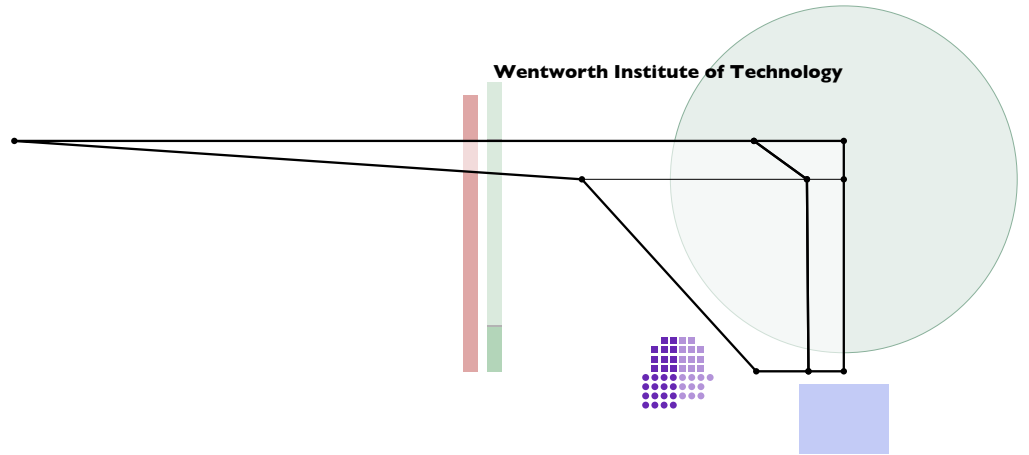

Woodbury University

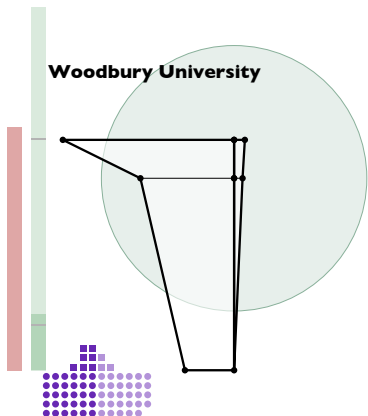

Yale University

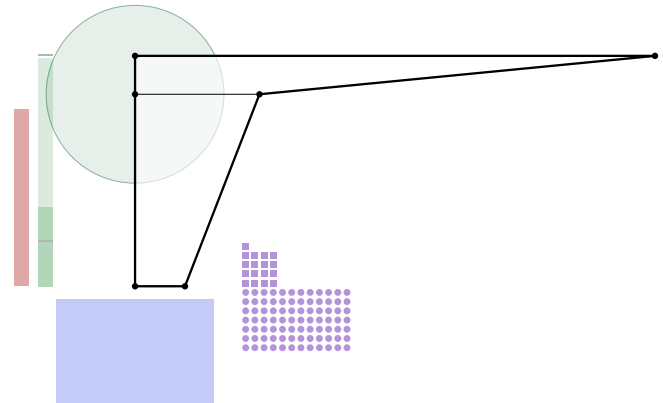

Appendix I

Sources of the data charted in the diagrams:

NAAB data:

2006_Stat_Report.xls

Annual Report Statistics worksheet 2005.xls

20071126_NAAB Accredited Programs.pdf

available at www.NAAB.org

2006 data was supplemented with 2005 data for schools not reporting in 2006. Of the 118 accredited schools, data for 23 schools is absent or insufficient for charting.

NCARB data:

http://ncarb.org/are/arepassrates_by_school.asp

http://ncarb.org/newsclips/may0507_arch_survey.html

available at www.NCARB.org

The data in these documents represent only one year, consequently atypical values may be depicted.

Statistics for ARE passing rates and IDP enrollment have not been made publicly available. NCARB annually publishes passing rates by test division. If a meaningful chart of the path to licensure is to be prepared, additional data must be procured, such as:

- IDP enrollment showing year and institution of degree
- ARE completion rates (successful passing of all divisions) showing year and institution of degree and jurisdiction of application.

Notes on the diagrams:

Note 1. AAG diagrams

AAG (application, acceptances, graduation) diagrams show the numbers of applicants, acceptances, and graduates for each of the reporting institutions. The proportion of accepted students who actually enroll at each school is unclear from the data. Acceptance rates (applicants/acceptances) vary from 6% to 96%, the average for all reporting programs is 44%. Graduating class size varies from 4 to 234, the average for all reporting programs is 90. The ratio of graduates to accepted students varies from 7% to 130%, with an average for all reporting schools of 33%. The reporting institutions reported 49,501 applications, 21,681 acceptances, and 7,203 graduates.

Page A of the diagrams presents the national average for the reporting institutions by type of degree.

NAAB does not accredit 4 year programs, but maintains statistical data for schools that offer them which are otherwise accredited.

Note 2. Enrollment diagrams

Enrollment diagrams show the number of total students reported as enrolled for each of the reporting schools. Student bodies for schools which offer multiple degree-types are combined. A circle is shown, its area proportioned to the size of the student body, using the same unit of area per person as was used for the faculty diagrams. Enrollment is charted by FTE (full-time equivalent) student data contained in the NAAB data. Enrollment varies from a low of 16 to a high of 940; the average for reporting schools is 366. The total enrollment of the reporting institutions is approximately 36,000. Annual tuition totals approximately \$700,000,000 (approximately \$100,000 per graduate).

The enrollment figures in the NAAB data appear to contain anomalies that are difficult to reconcile; enrollment figures are also missing from numerous schools.

Note 3. Faculty diagrams

Faculty diagrams show the number of faculty members reported for each institution. Faculty statistics are not broken down by degree-type. Full- and part-time faculty are shown, as are licensed and non-licensed faculty. Reported faculty size ranges from 7 to 385, with an average faculty of 43. Nationally, accredited institutions report that 46% of the faculty is licensed to practice architecture, and that 42% of faculty members are categorized as practitioners. Practitioners have not been identified in the charts.

Note 4. Matriculation Latency

Matriculation Latency is defined as the ratio of the total school enrollment in proportion to the number of graduates multiplied by the number of years required for the degree they have earned. This ratio is sensitive to unique conditions and can be considered accurate only if calculated over a number of years; these diagrams represent data from one year only and are not definitive.

Ratios for the reporting institutions for the year in question vary from a low of 0.51 to a high of 7.34. In some cases this variance may be attributable to erroneous enrollment figures. The average ratio for all reporting schools is 1.30; this value was used as the calibration length of the bar in the charts. Average matriculation latency ratios for the various degree types are shown on page B.

Note 5. IDP and ARE

This project charts the path to licensure, mapping statistical data for accredited schools of architecture, and intended to plot the duration of IDP and ARE passing rates for their graduates.

NCARB publicizes the numbers of ARE test-divisions attempted and passed. This data has been charted. The chart currently sheds no light on overall ARE success rates or IDP duration, an understanding of which is essential to assessing the efficacy of the system in place today.

The charts for ARE pass rates by division portray the number of attempted test sections as width and the number of passed sections as height. A square would indicate perfect passing scores.

Passing rates by school vary between 29% and 94%; average overall passing rates for the nine ARE test divisions was 70.2%. NCARB reports that 40,069 test divisions were attempted; of these 28,125 were passed. Aggregate national figures for each division are shown on page C. It can not be determined from the data available how many unique applicants took any division, nor can the time elapsed from graduation to the initiation or successful completion of the ARE, or each exam division.

Note 6. Typologies

The AAG diagrams for the reporting institutions fall into four general categories, derived by inspection. These are shown in Figure 1.

Note 7. Geography

The Geographic distribution of licensed architects, architecture students, and accredited schools of architecture is shown in Figure 2.

Note 8. Ordering

The diagrams that precede this Appendix are ordered alphabetically, by name of institution. In the attached Figure 3. they are arranged by size of graduating class, from smallest to largest.

Note 9. IDP

It would be valuable to chart the outcome of IDP experience in relation to the size and type of firm as well as according to length of employment and other factors.

Plea:

The effort required to obtain the data necessary to complete this map is small in comparison to the investment in education and internship being made daily, and even smaller in comparison to the value of securing a clear picture of the status quo.

In order to complete this chart of the path to licensure, the information described in Notes 5 and 9 must be obtained. Any other information deemed relevant by the stakeholders should also be included in the final mapping.

Please, let's gather this information - for 5, 7, or preferably 10 years, and arrange it in such a way that we can see and understand the terrain we face.

Respectfully submitted,

Matthew Arnold AIA, NCARB

cc. Lee Mitgang, Edward Tufte

Accredited Schools of Architecture in the US (118 programs)

M	Academy of Art University	M	Savannah College of Art and Design
M	Andrews University	Mc	School of the Art Institute of Chicago
M	Arizona State University	M B	Southern California Institute of Architecture
B	Auburn University	B	Southern Polytechnic State University
M	Ball State University	B	Southern University and A & M College
M B	Boston Architectural College	M	SUNY at Buffalo
Mc B	California College of Arts and Crafts	M B	Syracuse University
B	California Polytechnic State University-San Luis Obispo	B	Temple University
B	California State Polytechnic University-Pomona	M	Texas A & M University
B	Carnegie Mellon University	M	Texas Tech University
M	Catholic University of America	M	Tulane University of Louisiana
M	Clemson University	Bc	Tuskegee University
M	Columbia University in the City of New York	B	University of Arizona
B	Cooper Union for the Advancement of Science and Art	B	University of Arkansas
Mc B	Cornell University	M	University of California-Los Angeles
Mc B	CUNY City College	M	University of California at Berkeley
B	Drexel University	M	University of Cincinnati
B	Drury University	M	University of Colorado
M B	Florida Agricultural and Mechanical University	M	University of Detroit Mercy
B	Florida Atlantic University	M	University of Florida
M	Florida International University	Mc	University of Hartford
M	Frank Lloyd Wright School of Architecture, Taliesin	D	University of Hawaii
M	Georgia Institute of Technology	M B	University of Houston
M	Hampton University	M	University of Idaho
M	Harvard University	M	University of Illinois at Chicago
B	Howard University	M	University of Illinois at Urbana-Champaign
M B	Illinois Institute of Technology	M	University of Kansas
M B	Iowa State University	B	University of Kentucky
M	Judson University	M	University of Louisiana at Lafayette
M	Kansas State University	M	University of Maryland
M	Kent State University	M	University of Massachusetts
M	Lawrence Technological University	M B	University of Miami
M B	Louisiana State University	M	University of Michigan
M	Louisiana Tech University	M	University of Minnesota
Mc	Massachusetts College of Art	M	University of Nebraska at Lincoln
M	Massachusetts Institute of Technology	M	University of Nevada-Las Vegas
M	Miami University	M	University of New Mexico
B	Mississippi State University	M B	University of North Carolina at Charlotte
M	Montana State University	M B	University of Notre Dame
M	Morgan State University	M B	University of Oklahoma
B	New Jersey Institute of Technology	M B	University of Oregon
M B	New School of Architecture	M	University of Pennsylvania
B	New York Institute of Technology	M	University of Puerto Rico
M B	North Carolina State University	M	University of South Florida
M	North Dakota State University	M B	University of Southern California
M	Norwich University	M B	University of Tennessee
M	Ohio State University	M	University of Texas at Arlington
B	Oklahoma State University	M B	University of Texas at Austin
M	Parsons School of Design	M	University of Texas at San Antonio
B	Pennsylvania State University	M	University of Utah
B	Philadelphia University	M	University of Virginia
B	Polytechnic University of Puerto Rico	M	University of Washington
M	Prairie View A & M University	M	University of Wisconsin-Milwaukee
M B	Pratt Institute	M B	Virginia Polytechnic Institute and State University
M	Princeton University	M	Washington State University
M B	Rensselaer Polytechnic Institute	M	Washington University in St Louis
M B	Rhode Island School of Design	B	Wentworth Institute of Technology
M B	Rice University	B	Woodbury University
M	Roger Williams University	M	Yale University

NAAB does not accredit
4-year preprofessional Architecture Programs
but does maintain statistical data for
schools which have other accredited programs.

data presented for schools listed in **bold face**
from NAAB statistics for 2005 & 2006

M Masters Program
B Bachelors Program
D Doctorate Program
c candidate Program

**Figure I.
Typologies**

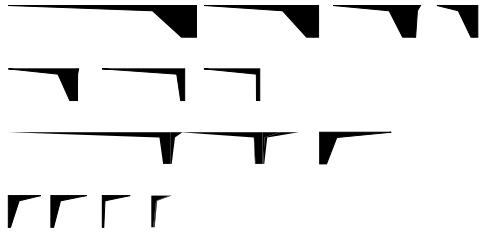

PENNANT

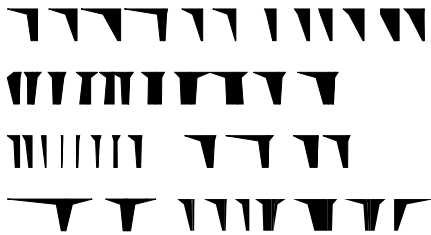
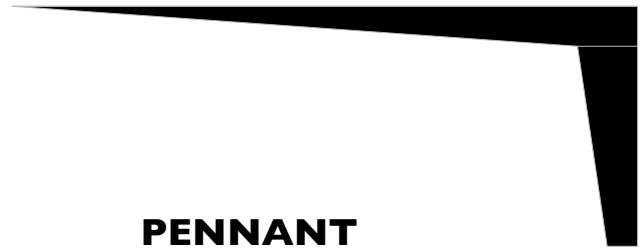

TORCH

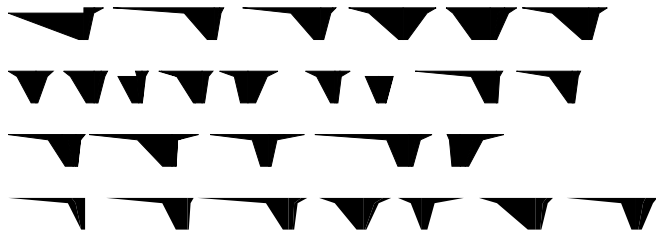
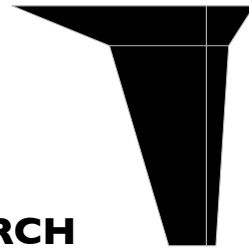

FUNNEL

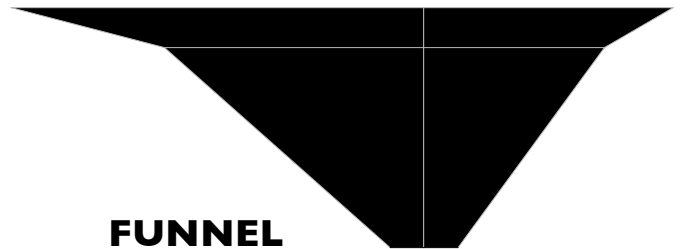

WEDGE

